

# Ceiling & Floor Fan Coil Units

- 1. **Features** ..... 2
- 2. **External Appearance** ..... 2
- 3. **Products Lineup** ..... 3
- 4. **Nomenclature** ..... 3
- 5. **Specifications** ..... 4
- 6. **Dimensions** ..... 7
- 7. **Service Spaces** ..... 9
- 8. **Wiring Diagrams** ..... 10
- 9. **Installation** ..... 11
  - 9.1 **Transport and handling** ..... 11
  - 9.2 **Storage conditions** ..... 11
  - 9.3 **Service spaces** ..... 11
  - 9.4 **Units installation** ..... 12
  - 9.5 **Electrical connections** ..... 15
  - 9.6 **Maintenance** ..... 16

### 1. Features

#### Flexible for installation, designed for horizontal/vertical, concealed/cabinet application

Ceiling Installation



Floor Installation



Concealed Installation



#### High efficiency and low operating sound level

Thanks to the DC Fan Motor, the unit operates in lower power consumption and lower operating sound level.

#### Meet CE certification requirements

The unit can meet the latest CE certification requirements for using DC Fan Motor.



#### Air return form side or below for flexible choice



#### Movable louver makes wide angle air flow

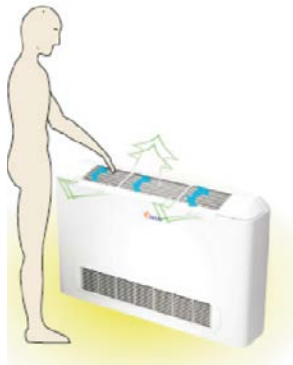

### 2. External Appearance

Cased Type (H4 Series)  
Standard



Cased Type (H5 Series)  
Optional



Uncased Type (H3 Series)  
Optional



### 3. Products Lineup

Model	Air volume (CFM)	Power supply
MKH3-V150/MKH4-V150/MKH5-V150	150	220~240V-1Ph-50Hz
MKH3-V250/MKH4-V250/MKH5-V250	250	
MKH3-V300/MKH4-V300/MKH5-V300	300	
MKH3-V400/MKH4-V400/MKH5-V400	400	
MKH3-V450/MKH4-V450/MKH5-V450	450	
MKH3-V500/MKH4-V500/MKH5-V500	500	
MKH3-V600/MKH4-V600/MKH5-V600	600	
MKH3-V800/MKH4-V800/MKH5-V800	800	
MKH3-V900/MKH4-V900/MKH5-V900	900	

### 4. Nomenclature

**M K H4 – V 150**

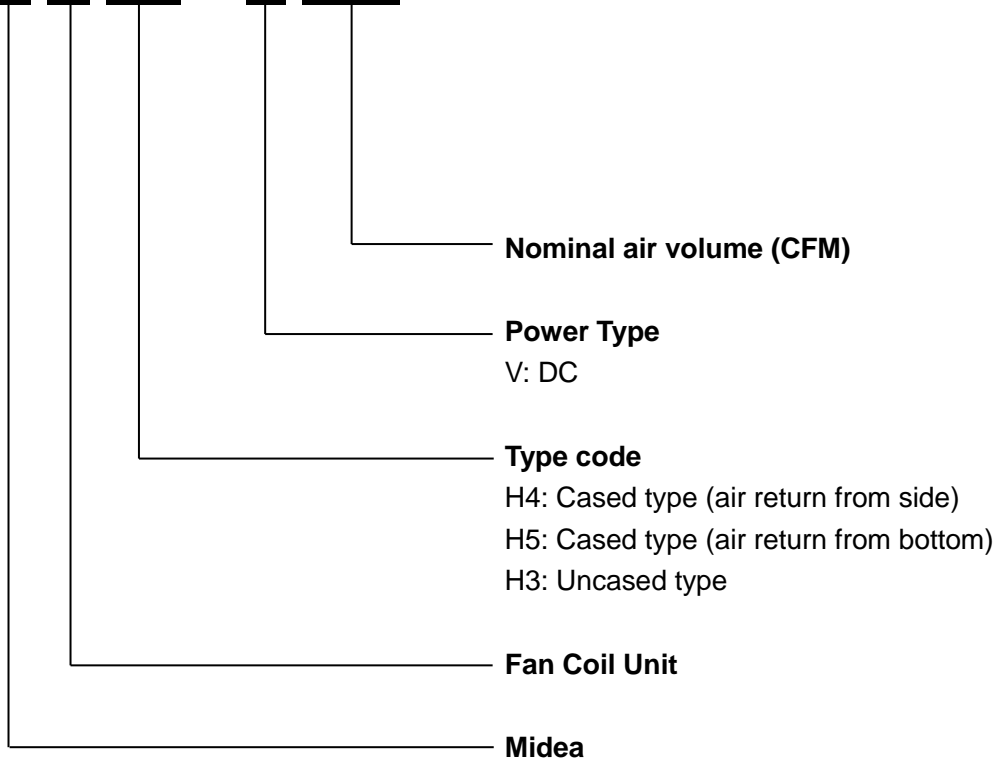

## 5. Specifications

Model			MKH3-V300	MKH3-V300	MKH3-V300
			MKH4-V300	MKH4-V300	MKH4-V300
			MKH5-V500	MKH5-V500	MKH5-V500
Power supply		V/Ph/Hz	220-240/1/50		
Air flow(H/M/L)		m <sup>3</sup> /h	255/215/190	425/360/320	510/430/380
		CFM	150/125/110	250/210/190	300/250/220
Cooling	Capacity (H/M/L)	kW	1.74/1.31/1.05	1.84/1.48/1.18	2.84/2.21/1.63
	Water flow rate	L/h	299	316	488
	Water pressure drop	kPa	8.5	9.6	16.3
Heating	Capacity (H/M/L)	kW	2.04/1.42/1.25	2.20/1.66/1.28	3.68/2.77/1.99
	Water pressure drop	kPa	8	7.7	14.5
Power input		W	12	15	26
Sound pressure level	H3 (H/M/L)	dB(A)	29/25/19	30/26/20	32/28/22
	H4 (H/M/L)	dB(A)	30/26/20	31/27/21	33/29/23
	H5 (H/M/L)	dB(A)	29/25/19	30/26/20	32/28/22
Fan motor	Type	DC motor			
	Quantity	1			
Fan	Type	Centrifugal, forward-curved Blades			
	Quantity	1	1	2	
Coil	Row		3	3	2
	Max. working pressure	MPa	1.6		
	Diameter	mm	Φ9.52		
Body (H3 series)	Net dimensions (W×H×D)	mm	550×545×212	550×545×212	750×545×212
	Packing size (W×H×D)	mm	639×639×305	639×639×305	839×639×305
	Net weight	kg	17	17	20
	Gross weight	kg	19	19	23.5
Body (H4/H5 series)	Net dimensions (W×H×D)	mm	800×592×220	800×592×220	1000×592×220
	Packing size (W×H×D)	mm	889×683×312	889×683×312	1089×683×312
	Net weight	kg	24.4	24.4	28.2
	Gross weight	kg	28.4	28.4	33.2
Water inlet/outlet pipe		inch	G3/4		
Drain pipe		mm	ODΦ16		

### Note:

1. H: High fan speed; M: Medium fan speed; L: Low fan speed.

2. Cooling conditions: Entering water 7°C, Leaving water 12°C, Entering air temperature 27°C DB/19°C WB.

Heating\* conditions: Entering water 50°C, the same water flow as the cooling conditions, Entering air temperature 20°C DB.

Heating\*\*conditions: Entering water 70°C, Leaving water 60°C, Entering air temperature 20°C DB.

3. Noise is tested in a semi-anechoic test room.

Model			MKH3-V400	MKH3-V450	MKH3-V500
			MKH4-V400	MKH4-V450	MKH4-V500
			MKH5-V400	MKH5-V450	MKH5-V500
Power supply		V/Ph/Hz	220-240/1/50		
Air flow(H/M/L)		m <sup>3</sup> /h	680/580/510	765/650/570	850/720/640
		CFM	400/340/300	450/380/335	500/420/375
Cooling	Capacity (H/M/L)	kW	3.03/2.41/1.72	4.43/3.21/2.52	4.74/3.53/2.55
	Water flow rate	L/h	521	762	815
	Water pressure drop	kPa	19.3	30.1	27.7
Heating	Capacity (H/M/L)	kW	3.87/2.95/2.09	5.52/3.94/2.98	5.77/4.23/3.03
	Water pressure drop	kPa	16.6	25.3	23.1
Power input		W	30	26	32
Sound pressure level	H3 (H/M/L)	dB(A)	34/30/24	36/32/26	38/33/27
	H4 (H/M/L)	dB(A)	35/31/25	37/33/27	39/34/28
	H5 (H/M/L)	dB(A)	34/30/24	36/32/26	38/33/27
Fan motor	Type		DC motor		
	Quantity		1		
Fan	Type		Centrifugal, forward-curved Blades		
	Quantity		2	2	2
Coil	Row		2	3	3
	Max. working pressure	MPa	1.6		
	Diameter	mm	Φ9.52		
Body (H3 series)	Net dimensions (W×H×D)	mm	750×545×212	950×545×212	950×545×212
	Packing size (W×H×D)	mm	839×639×305	1039×639×305	1039×639×305
	Net weight	kg	20	25	25
	Gross weight	kg	23.5	29	29
Body (H4/H5 series)	Net dimensions (W×H×D)	mm	1000×592×220	1200×592×220	1200×592×220
	Packing size (W×H×D)	mm	1089×683×312	1289×683×312	1289×683×312
	Net weight	kg	28.2	34.2	34.2
	Gross weight	kg	33.2	39.7	39.7
Water inlet/outlet pipe		inch	G3/4		
Drain pipe		mm	ODΦ16		

**Note:**

1. H: High fan speed; M: Medium fan speed; L: Low fan speed.

2. Cooling conditions: Entering water 7°C, Leaving water 12°C, Entering air temperature 27°C DB/19°C WB.

Heating\* conditions: Entering water 50°C, the same water flow as the cooling conditions, Entering air temperature 20°C DB.

Heating\*\*conditions: Entering water 70°C, Leaving water 60°C, Entering air temperature 20°C DB.

3. Noise is tested in a semi-anechoic test room.

Model			MKH3-V600	MKH3-V800	MKH3-V900
			MKH4-V600	MKH4-V800	MKH4-V900
			MKH5-V600	MKH5-V800	MKH5-V900
Power supply		V/Ph/Hz	220-240/1/50		
Air flow(H/M/L)		m <sup>3</sup> /h	1020/870/765	1360/1160/1020	1530/1300/1150
		CFM	600/510/450	800/680/600	900/760/675
Cooling	Capacity (H/M/L)	kW	5.51/3.92/2.99	5.88/4.77/3.61	6.87/5.32/4.31
	Water flow rate	L/h	948	1011	1182
	Water pressure drop	kPa	16.6	26.5	31.4
Heating	Capacity (H/M/L)	kW	7.00/5.11/3.86	8.01/6.34/4.75	9.24/6.89/5.51
	Water pressure drop	kPa	14.5	19.8	25.6
Power input		W	36	64	101
Sound pressure level	H3 (H/M/L)	dB(A)	40/34/28	41/35/29	43/37/31
	H4 (H/M/L)	dB(A)	41/35/29	42/36/30	44/38/32
	H5 (H/M/L)	dB(A)	40/34/28	41/35/29	43/37/31
Fan motor	Type		DC motor		
	Quantity		1		
Fan	Type		Centrifugal, forward-curved Blades		
	Quantity		3	3	3
Coil	Row		2	2	2
	Max. working pressure	MPa	1.6		
	Diameter	mm	Φ9.52		
Body (H3 series)	Net dimensions (W×H×D)	mm	1250×545×212	1250×545×212	1250×545×212
	Packing size (W×H×D)	mm	1339×639×305	1339×639×305	1339×639×305
	Net weight	kg	32	32	32
	Gross weight	kg	36	36	36
Body (H4/H5 series)	Net dimensions (W×H×D)	mm	1500×592×220	1500×592×220	1500×592×220
	Packing size (W×H×D)	mm	1589×683×312	1589×683×312	1589×683×312
	Net weight	kg	40	40	40
	Gross weight	kg	45.5	45.5	45.5
Water inlet/outlet pipe		inch	G3/4		
Drain pipe		mm	ODΦ16		

**Note:**

1. H: High fan speed; M: Medium fan speed; L: Low fan speed.

2. Cooling conditions: Entering water 7°C, Leaving water 12°C, Entering air temperature 27°C DB/19°C WB.

Heating\* conditions: Entering water 50°C, the same water flow as the cooling conditions, Entering air temperature 20°C DB.

Heating\*\*conditions: Entering water 70°C, Leaving water 60°C, Entering air temperature 20°C DB.

3. Noise is tested in a semi-anechoic test room.

## 6. Dimensions

### Cased type

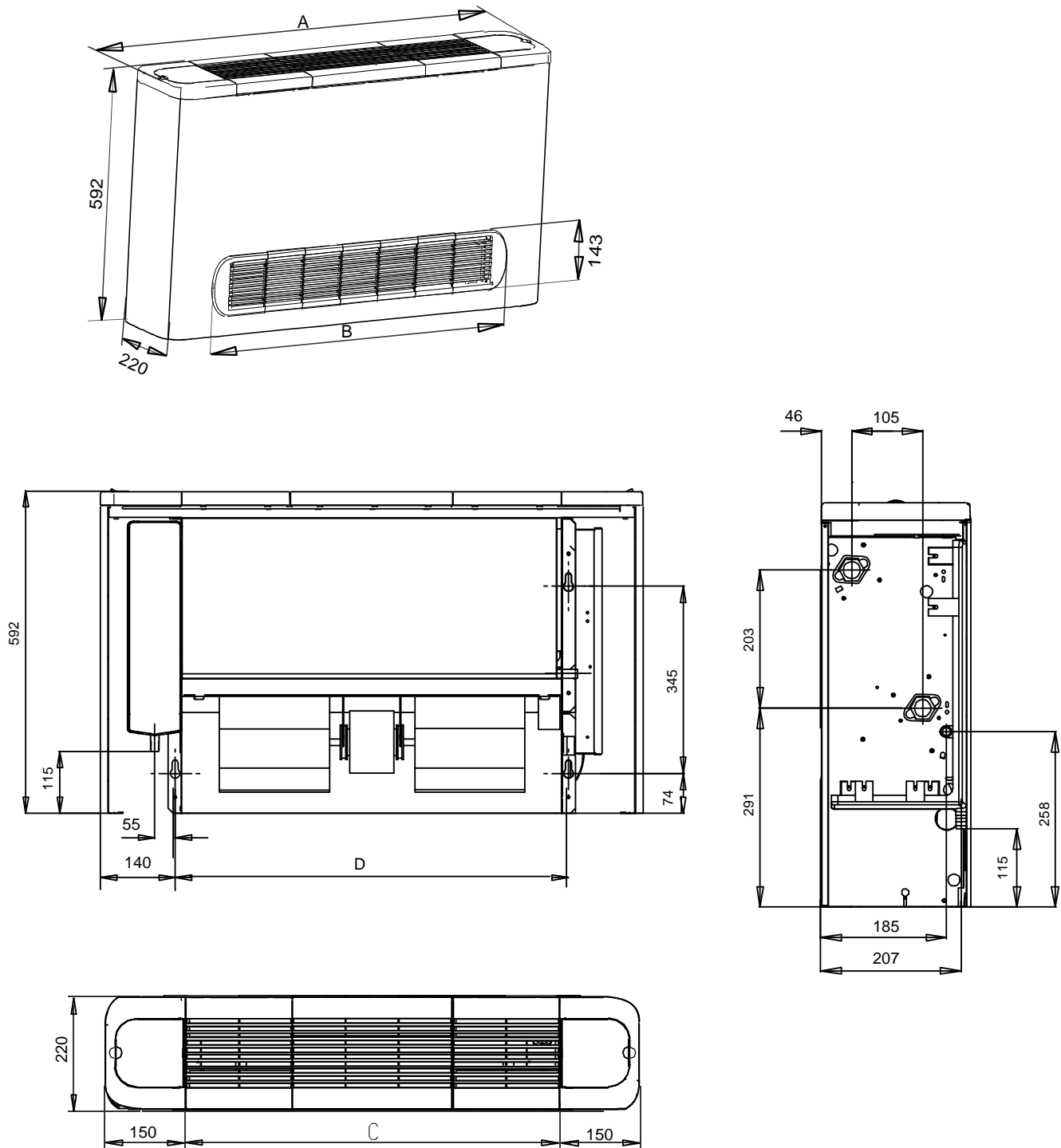

Dimensions (unit: mm)

Size	150	250	300	400	450	500	600	800	900
A	800	800	1000	1000	1200	1200	1500	1500	1500
B	584	584	784	784	984	984	1284	1284	1284
C	500	500	700	700	900	900	1200	1200	1200
D	526	526	726	726	926	926	1226	1226	1226

**Uncased type**

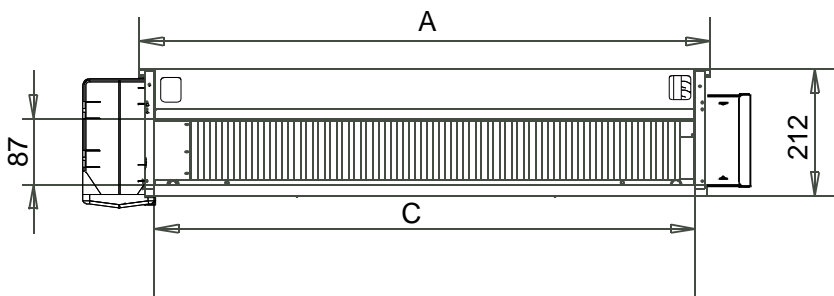
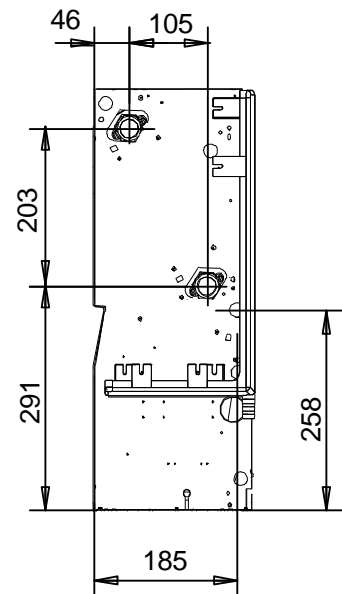
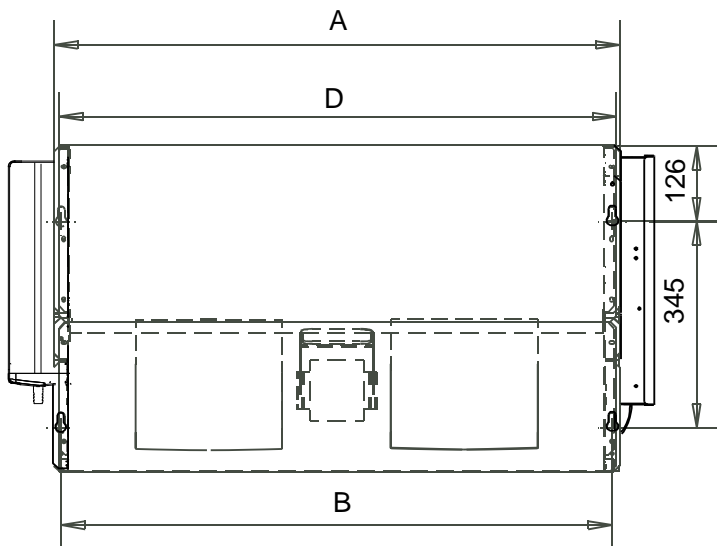
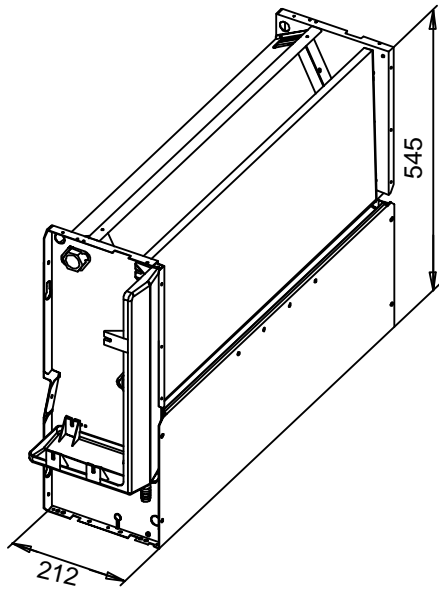

Dimensions (unit: mm)

Size	150	250	300	400	450	500	600	800	900
A	550	550	750	750	950	950	1250	1250	1250
B	526	526	726	726	926	926	1226	1226	1226
C	500	500	700	700	900	900	1200	1200	1200
D	532	532	732	732	932	932	1232	1232	1232



## 7. Service Spaces

### Cased type

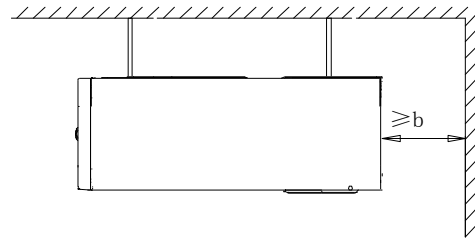
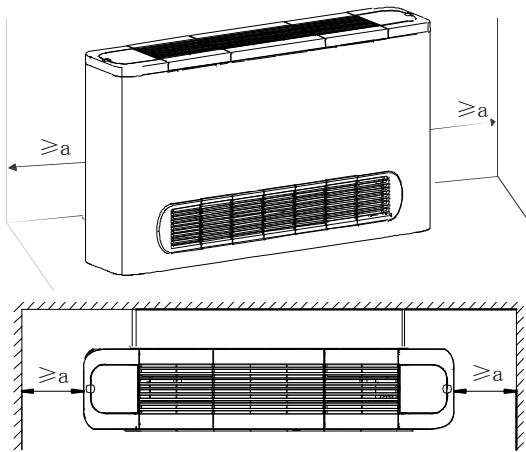

a (mm)	150
b (mm)	20

### Uncased type

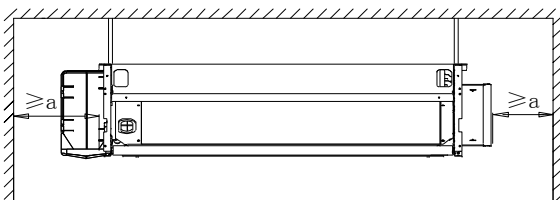
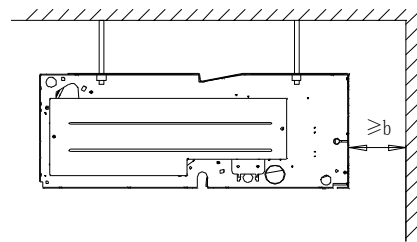
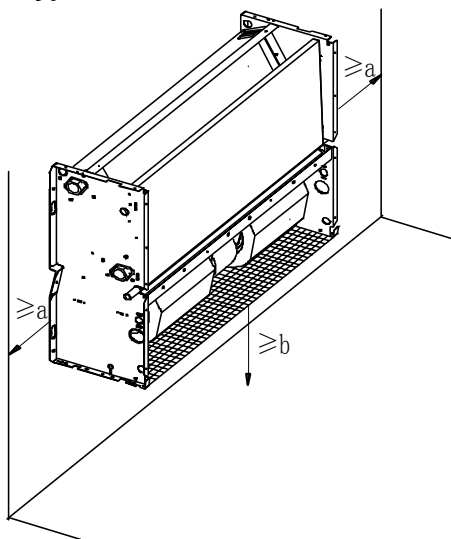

a (mm)	200
b (mm)	80

### 8. Wiring Diagrams

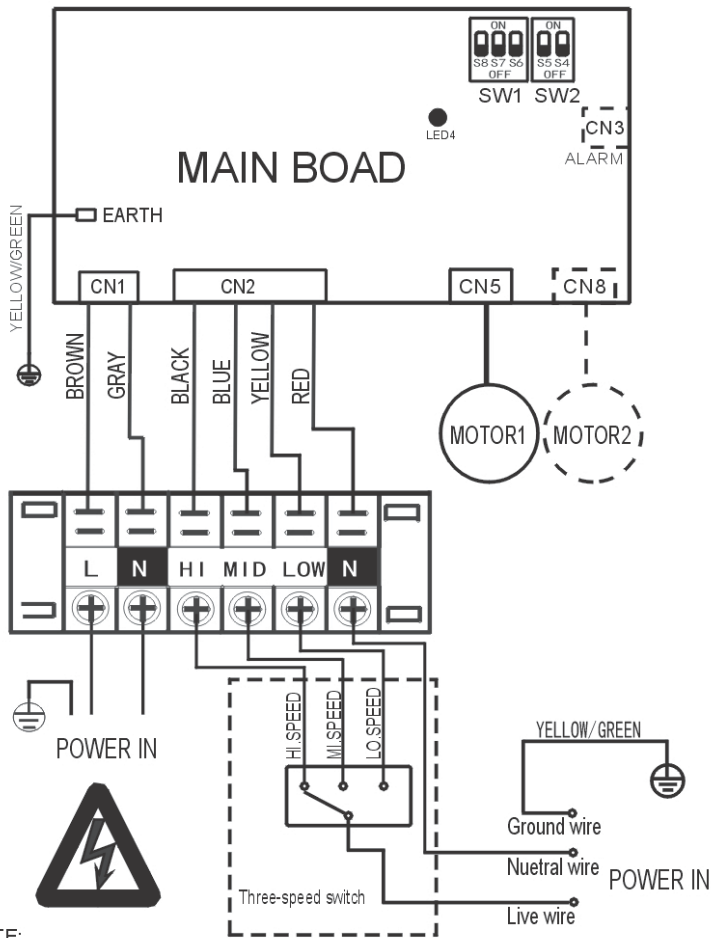

NOTE:  
 Connection of motor and main control panel: single-motor model should connect CN5,  
 for double-motor model, positions of CN5 and CN8 can be changed.

Mode	Dial code
FP-25.5	
FP-42.5	
FP-51	
FP-68	
FP-76.5	
FP-85	
FP-102	
FP-136	
FP-153	

## 9. Installation

### 9.1 Transport and handling

**Caution:**

Do not open or tamper with the packaging before installation. The units should only be moved and lifted by specialized personnel trained in these operations.

Check on arrival that the unit has not been damaged during transport and that it is complete with all its parts.

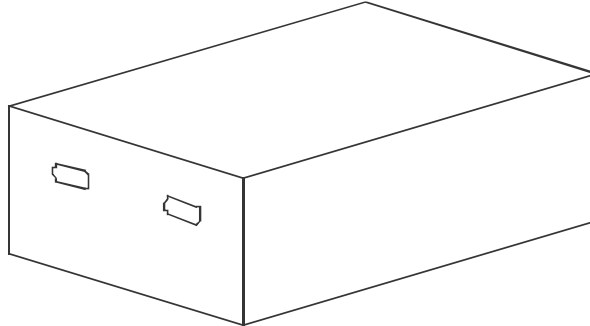

To remove the packaging, please follow below instructions:

1. Check for visible damage.
2. Open the packaging.
3. Check that the manual for use and maintenance are in the packaging.
4. Dispose of the packaging material in accordance with current legislation at the appropriate waste reception or recycling site.

The units may be moved or lifted either by hand or by means of a suitable trolley. If the weight of the unit is more than 30kg, moving units need to be moved at the same time, it is advisable to put the machines in a container and lift them by means of a crane or something similar.

### 9.2 Storage conditions

Units in packaging may be stacked not more than four-layer, and must be kept under cover.

### 9.3 Service spaces

**Caution:**

Incorrect positioning or installation of the unit may amplify noise levels and vibrations generated during operation.

Guarantee enough clearances for installation and maintenances.

#### Cased type

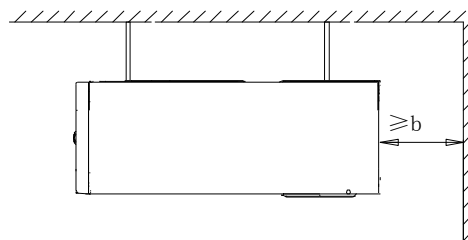
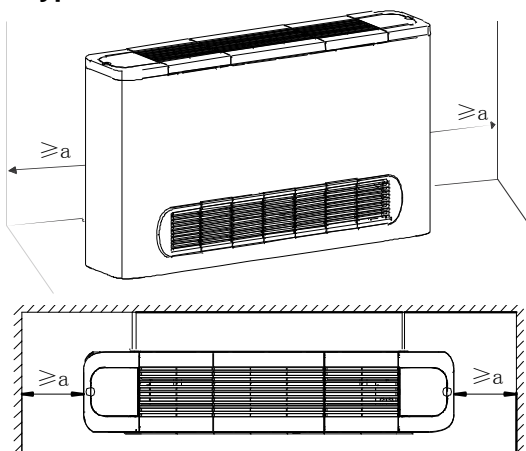

a (mm)	150
b (mm)	20

**Uncased type**

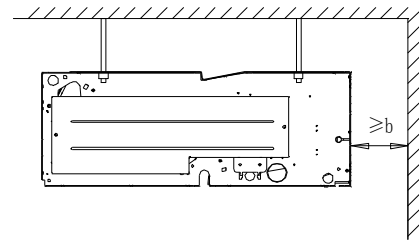
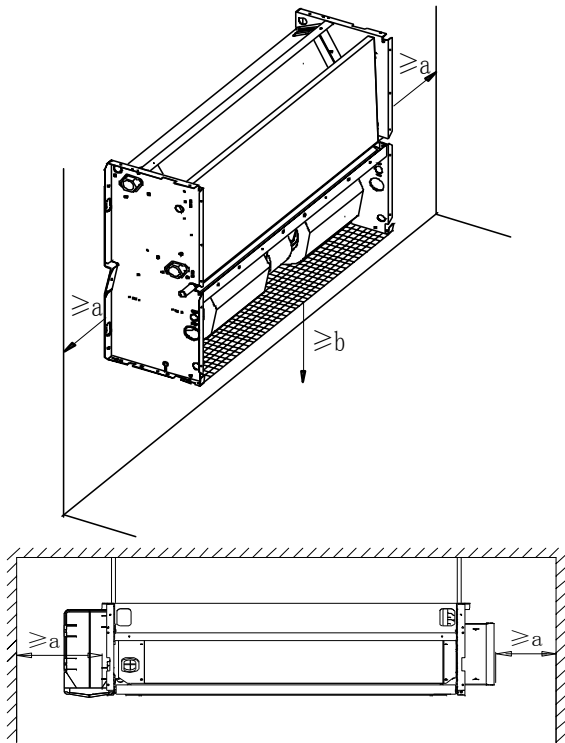

a (mm)	200
b (mm)	80

**9.4 Units installation**

**Caution:**

Installation must only be carried out by qualified technicians, trained to work with air-conditioning and refrigeration systems. Incorrect installation could lead to unit malfunctioning and a consequent deterioration in performance.

For installation, follow the instructions set out below:

Remove the external casing, unscrewing the screws which secure it to the structure, as following indicated.

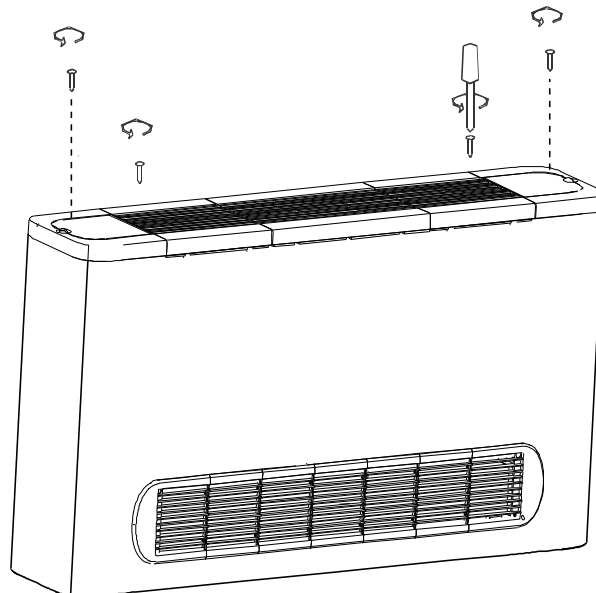

Parts instruction:

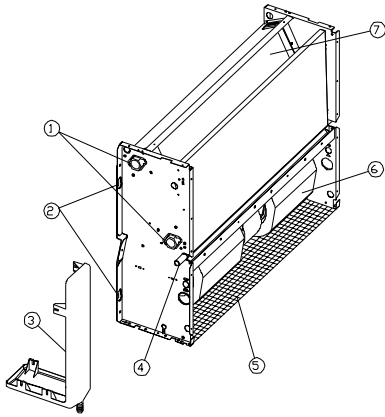

1. Pipe connections;
2. Fixing slots;
3. Defrosting tray;
4. Condensate discharge;
5. Air filter;
6. Fans;
7. Heat exchanger;

Mark out the fixing points on the wall or ceiling either by marking through the drillings in the unit or by referring to the measurements given in "7 DIMENSIONS". Maintain a gentle fall in the condensation drainage pipe, to ensure that water draining properly.

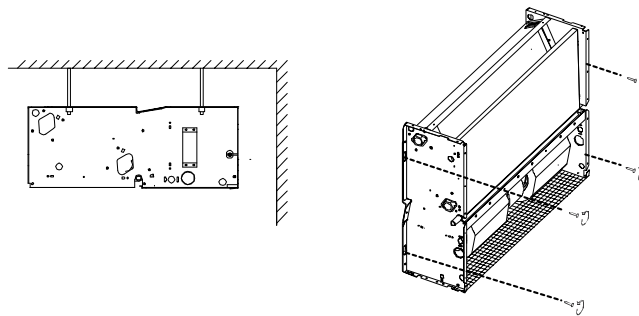

**Hydraulic connections**

It is most important that the hydraulic connections are made with great care by specialized fitters. Connect the unit to the water system by means of the fittings which are marked Flow and Return.

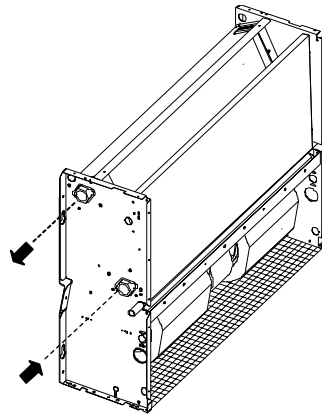

All the water coils including the optional extras are equipped with air release-valves next to the upper union and with water drain valves next to the lower union.

All the valves can be opened and closed with screwdrivers or allenkeys.

**Caution:**

The water coils can be partially drained through the drain valves.

To drain them completely, they should be blown out with an air-jet.

When installation is complete, it is necessary to:

Release the air contained in the circuit.

Lag the connection pipes and any valves coated with anti-condensation material 10 mm thick or install the auxiliary drain.

Pour water into the condensation collector tray and check that the liquid drains properly, following it right through to the exit of the drain tube. If it does not, check the fall and look for possible blockages.

**Setting up the condensate drainage system**

The condensation drainage system must be set up with an adequate fall to ensure that the water escapes properly.

Following are directions for setting up a proper condensation drainage system.

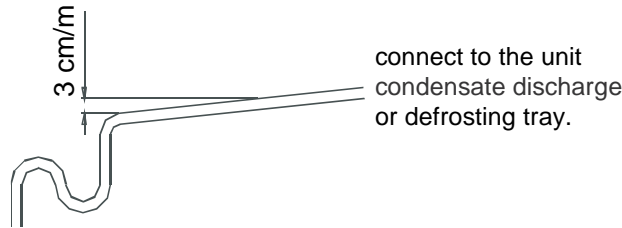

**Creation of the trap**

The condensation drainage system must be fitted with a suitable trap to prevent seepage of odours. Following are directions for setting up the trap.

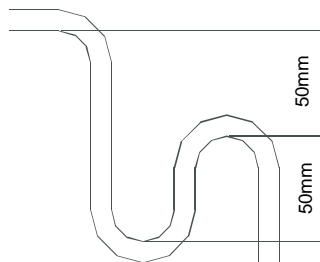

Always provide a drain plug at the bottom of the trap, and arrange it so that it can be quickly dismantled

**How to turn the coil round from fittings on the left (standard) to fittings on the right.**

The unit is supplied as standard with connections to the coil on the left. It is possible to turn the coil round to achieve connection on the right.

The operation of turning the principal and supplementary coils round can be carried out on site, but it is preferable to do it before installation on solid ground.

**Procedure to reverse the coil:**

1. Remove the casing (for casing type);
2. Remove the screws on both sides which hold the coil to the structure of the unit;
3. Turn the coil round in the direction indicated in Fig;
4. Re-fit the coil mounting screws;
5. Re-fit the casing (for casing type)

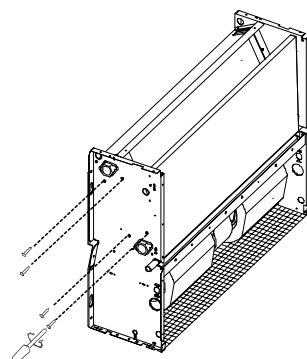

**Antifrost protection**

If the unit is not used during the winter the water contained in the system may freeze.

Draining the water circuit needs to be undertaken in good time. However, if the operation of draining the system is too laborious, a suitable quantity of antifreeze may be mixed with the water instead.

## 9.5 Electrical connections

### Caution:

Electrical connection of the unit must be carried out by qualified personnel in compliance with the regulations in effect in the country where the unit is installed. The company shall not be held liable for damage to persons or property caused by incorrect electrical connection.

The power cord type designation is H05RN-R or above/H07RN-F.

This appliance can be operated by children aged from 8 years and above and persons with reduced physical sensory or mental capabilities or lack of experience and knowledge, if they have been given supervision or instruction concerning use of the appliance in a safe way and understand the hazards involved. Children shall not play with the appliance. Cleaning and user maintenance shall not be made by children without supervision. The appliance shall be installed in accordance with national wiring regulations.

### Danger!

Always install a general automatic switch in a protected area near the appliance with an adequate capacity characteristic delayed curve with sufficient breaking power. There should be a minimum distance of 3mm between the contacts. Earth connection is compulsory by law to ensure user safety while the machine is in use.

Air flow	255-1530 m <sup>3</sup> /h
Power supply voltage	220-240V
Power supply phase	1 phase
Power supply frequency	50Hz
Circuit breaker / Fuse	15A / 15A

### Wiring

- ♦ See product wiring nameplate.
- ♦ Check that the voltage and the frequency of the power supply correspond to 220-240V single phase at 50Hz; that the available power is sufficient for the running the equipment; and that the supply cables are of adequate section for the maximum current which will be required.
- ♦ Make sure that the power supply system complies with current national safety regulations.
- ♦ Electrical connections must be made in accordance with the wiring diagrams supplied with the machine. For connection to the power supply network, use double-insulated flexible cable, twin pole + earth, section 1.5mm<sup>2</sup>, type H05RN-F.
- ♦ Pass the power supply cable through the slot beside the air filter. Use the cable clamp provided on the inner side of the panel to secure the power supply cable and the connecting cables, and strip only the length of cable needed to go into the connector block. In the event that the unit is mounted on a metal surface, earth connections must be made in compliance with local regulations. If the optional extra electric heating element is fitted, a separate power supply must be provided. Use double-insulated flexible cable, twin pole + earth, section 2.5mm<sup>2</sup>, type H05RN-F.

### Startup instructions

#### Caution:

Machine commissioning or the first startup must be carried out by skilled personnel qualified to work on this type of product.

Before starting up, make sure that the installation and electrical connections have been carried out in accordance with the instructions in this manual. Also make sure that there are no unauthorized persons in the vicinity of the machine during these operations.

#### **Pipeline system has been vacuumed before initial start the equipment.**

1. Remove the connecting pipe's side cover panel by cross screwdriver.
2. Remove the bolts that showed at the figure by slotted screwdriver. Start up the pump to circulate the

pipeline water and vacuum air from the system until there have water flow out from bolt holes, and then tighten the bolts of the system.

3. Shutdown the system that showed at the figure by slotted screwed and replaces the side cover panel.

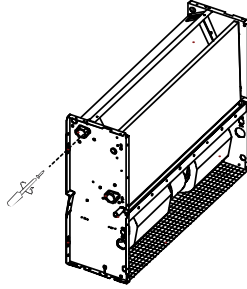

### Preliminary checks before startup

- ♦ Before starting up the unit, make sure that:
- ♦ The unit is positioned correctly;
- ♦ The flow and return pipes of the water system are correctly connected;
- ♦ The pipes are clean and free of air;
- ♦ The unit falls correctly towards the drainage outlet and the trap;
- ♦ The heat-exchangers are clean;
- ♦ The electrical connections are correct;
- ♦ The screws holding the cables are well tightened;
- ♦ The supply voltage is as required;
- ♦ The power consumption of the blower is correct and does not exceed the maximum permitted.

## 9.6 Maintenance

### Caution:

Maintenance work must only be carried out by qualified technicians authorized to work on air-conditioning and refrigeration systems.

Use suitable work gloves.

Do not use pointed objects through the air intake grilles.

Disconnect the power supply before cleaning and maintenance.

Use dry cloth to clean the unit.

Always disconnect the unit from the mains power supply at the main isolator switch before carrying out maintenance work or checks. Make sure that no one accidentally supplies power to the machine; lock the main switch in the Off position.

### Scheduled maintenance

- ♦ Once a month

Check the state of cleanliness of the air filters. The air filters are made of fibre and are washable in water. The state of cleanliness of the filters must be checked regularly at the start of the operating season and on a monthly basis.

- ♦ Every six months

Check the state of cleanliness of the heat-exchanger and the condensation drain-tube.

Switch off the unit, remove the casing of the machine and check the state of the heat-exchanger and the condensation drain-tube if necessary:

1. Remove any obstacle from the surface which may obstruct air flow;
2. Clean the dust with a jet of compressed air;
3. Wash and brush gently with water;
4. Dry with a jet of compressed air;
5. Check that there are no obstacles in the condensation drain tube which could prevent the normal flow of water.



**Release the air in the water system.**

1. Remove the casing of the machine (for casing type);
2. Start the system and run for a few minutes;
3. Stop the system;
4. Loosen the release screw on the inlet manifold and release the air.
5. Repeat the operation several times until no more air comes out of the system.

**At the end of the season**

To avoid the risk of rupture due to freezing, it is advisable to drain the water from the system at the end of every season.

**Check the electrical circuit**

The following operations are recommended for the maintenance of the electrical circuit:

Tighten the electrical contacts and terminals;

Check the unit's power using a clip-on ammeter and compare with the values shown on the document.

**Replace the fan assembly**

In case of burnout of the fan motor, it is necessary to replace the entire fan assembly.

Procedure for removal of the fan motor:

1. Remove the casing (for case type)
2. Disconnect the power supply cable from the fan motor;
3. Remove the screws on both sides which hold the motor to the unit;
4. Take out the fan assembly;
5. Install a new fan assembly.

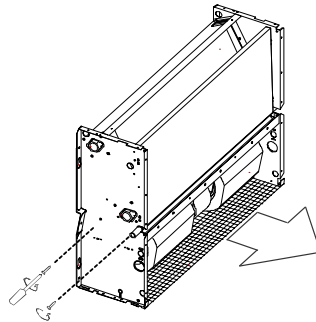
**Replace the heat-exchanger coil**

1. Procedure for removal of the heat-exchanger:
2. Isolate the inlet and outlet water pipes;
3. Disconnect the coil from the water system;
4. Remove the screws on both sides which hold the coil to the unit;
5. Take out the heat-exchanger coil;
6. Install a new heat-exchanger coil.

